

STAIRWAYS AND GUARDRAILS

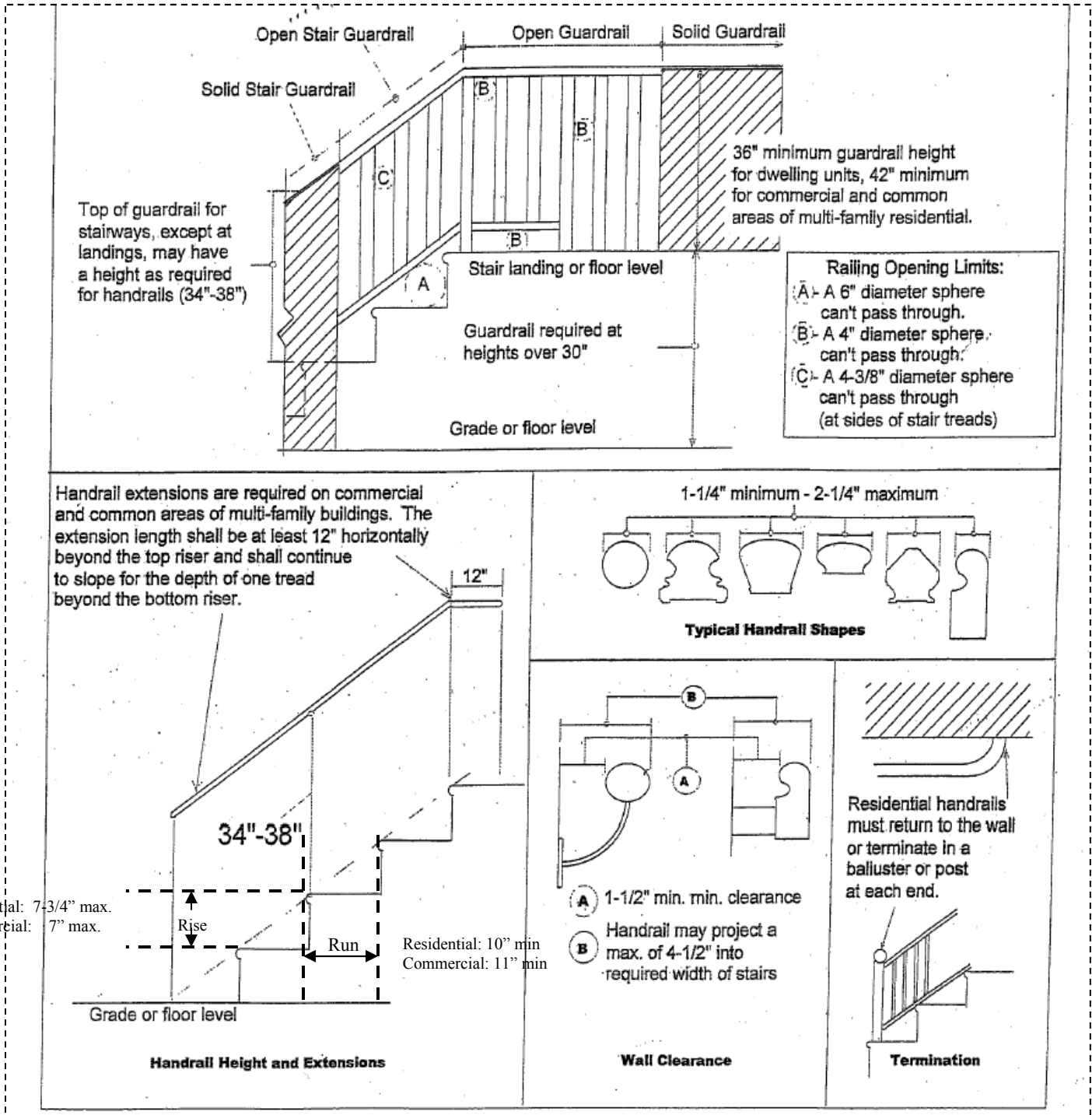

RESIDENTIAL WINDING STAIRS

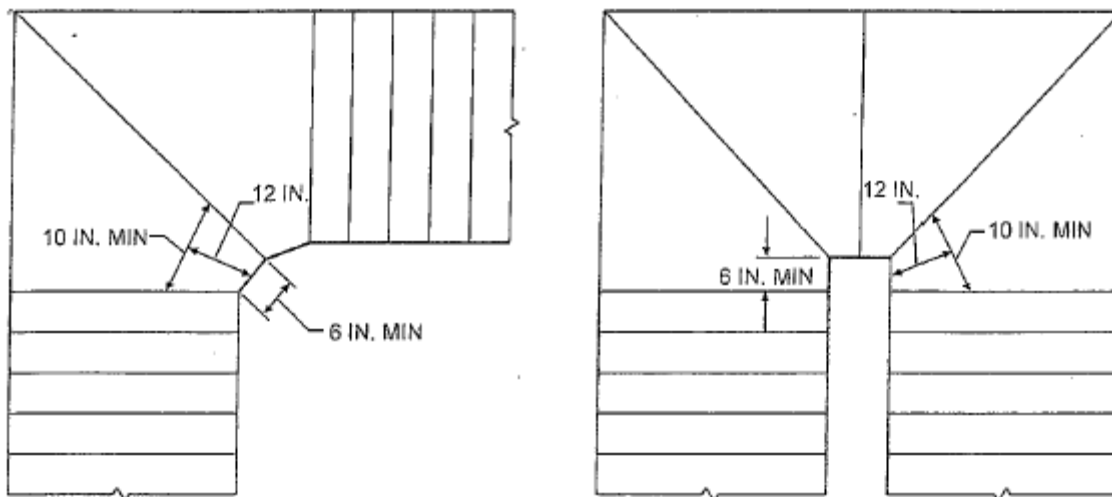

Figure R311.5.3.2(1)
WINDERS

Risers to be 7 3/4" max and headroom 6'-8" min.

CIRCULAR STAIRWAY

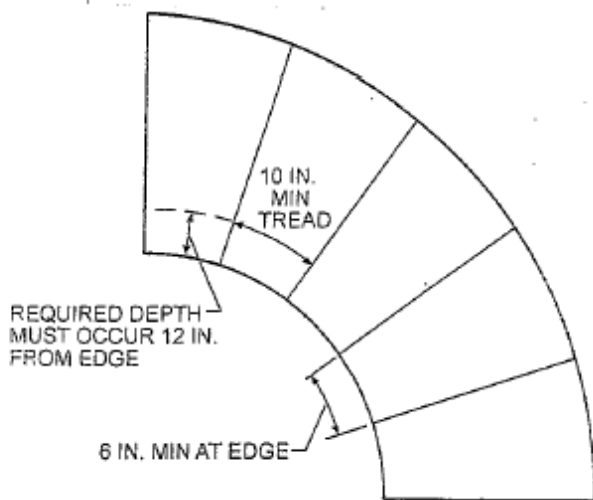

Figure R311.5.3.2(2)
WINDERS USED FOR CIRCULAR STAIRWAY

Risers to be 7 3/4" max and headroom to be 6'-8" min.

SPIRAL STAIRWAY

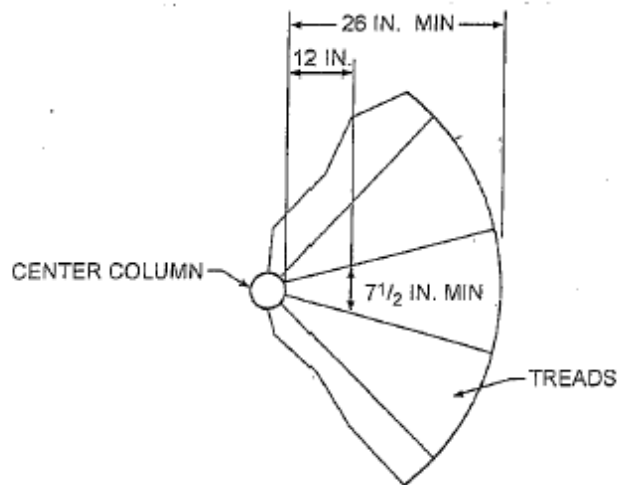

Figure R311.5.8.1
SPIRAL STAIRS

Spiral stair treads shall be identical, risers 9 1/2" and head room 6'-6" min.

NOTE: Handrails not shown for clarity.

**Grays Harbor County
Planning & Building Division**
Public Services Department
100 W Broadway Suite 31
Montesano, WA 98563
360-249-5579/360-249-3203 (fax)



pbd@co.grays-harbor.wa.us
www.co.grays-harbor.wa.us