

WATER HEATER INSTALLATION

Water heaters shall be anchored or strapped to resist horizontal displacement due to earthquake motion. Strapping shall be at points within the upper 1/3 and lower 1/3 of its vertical dimensions. At the lower point, a minimum distance of 4" shall be maintained above the controls with the strapping. UPC 508.2

Shut off valve on cold water

UPC 605.5

Flexible corrugated connectors

max. 24" in length

UPC 604.12

Insulate water lines

Cold R-3

Hot R-4

WSEC 503.11

T/P valve drain line to run to exterior pointing down 6" min. to 24" max. from ground.

UPC 608.5

Seismic straps top and bottom 1/3 of tank.

UPC 508.2

Tank ignition devices for gas are to be elevated $\geq 18"$ above floor and placed on R-10 pad if installed in unheated space or on concrete floor.

IMC 304.3 WSEC 504.2.1

When located in an attic, attic ceiling assemble, floor-ceiling assemble, or floor-subfloor assemble where damage may result from leaking, a corrosion resistant water-tight pan shall be installed beneath tank with 3/4" min. drain pipe run to exterior (separate from T/P valve drain line).

UPC 508.4

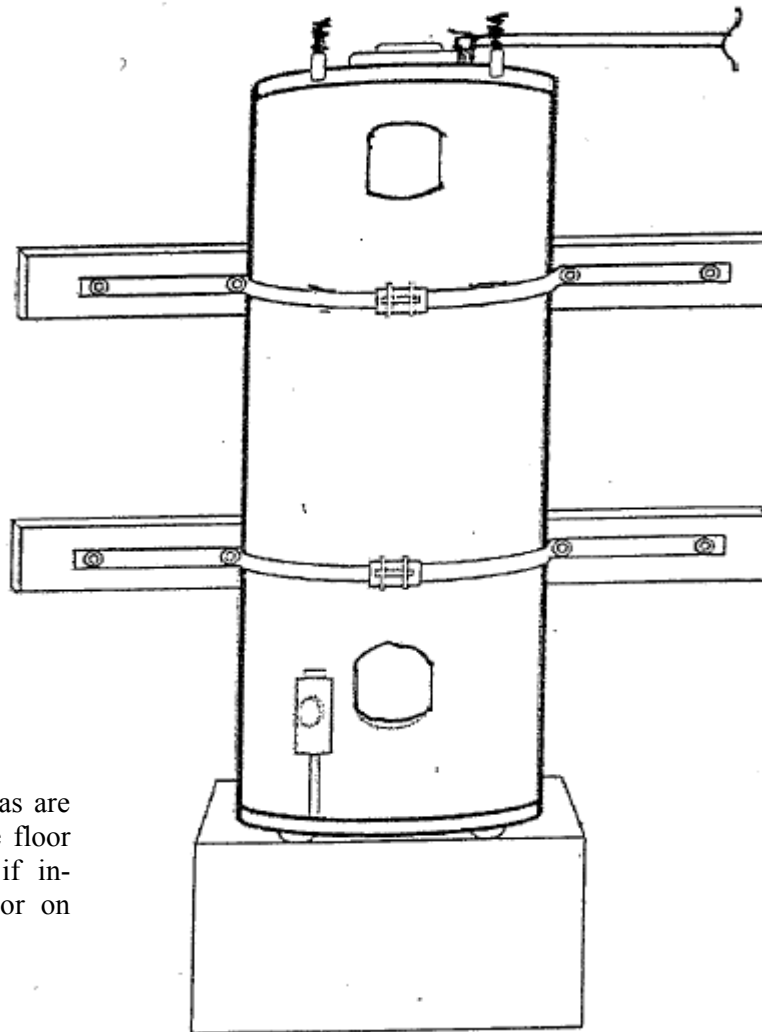

TABLE 5-1^{1,3}

Number of Bathrooms	1 to 1.5			2 to 2.5				3 to 3.5			
Number of Bedrooms	1	2	3	2	3	4	5	3	4	5	6
First Hour Rating ² , Gallons	42	54	54	54	67	67	80	67	80	80	80

Notes:

¹ The first hour rating is found on the "Energy Guide" label.

² Non-storage and solar water heaters shall be sized to meet the appropriate first hour rating as shown in the table.

³ For replacement water heaters, see Section 101.4.1.1.1.

Grays Harbor County
Planning & Building Division
Public Services Department
100 W Broadway Suite 31
Montesano, WA 98563
360-249-5579
360-249-3203 (fax)
pbd@co.grays-harbor.wa.us
www.co.grays-harbor.wa.us

