



**SOUTH COASTAL FLOOD HAZARD REDUCTION PLAN**  
**Grays Harbor County**  
**106786.PP.ZZ**  
**T. Platin**

**DRAINAGE SUB-BASIN**  
**CHARACTERISTICS**  
**for HEC-I Modelling**

Area I.D.	Area (sq ft)	Area (sq mi)	Tc (min)	CN
1	11,254,184	0.40	154	75
2	3,749,070	0.13	41	63
3	10,100,518	0.36	181	63
4	5,289,153	0.19	78	73
5	6,931,769	0.25	75	75

**FLOW PATH SCHEMATIC**

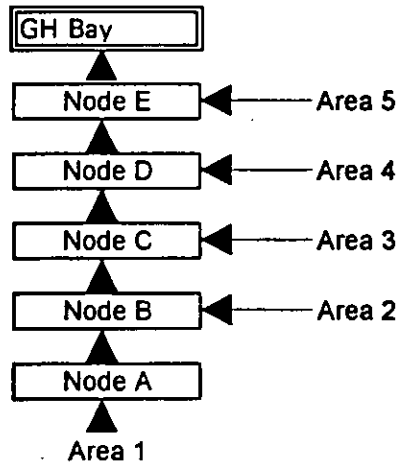



SUBJECT \_\_\_\_\_ BY \_\_\_\_\_ DATE \_\_\_\_\_

SHEET \_\_\_\_\_ OF \_\_\_\_\_

PROJECT NO. \_\_\_\_\_

# DRAINAGE BASINS FOR HEC-7 MODELING



Not to Scale

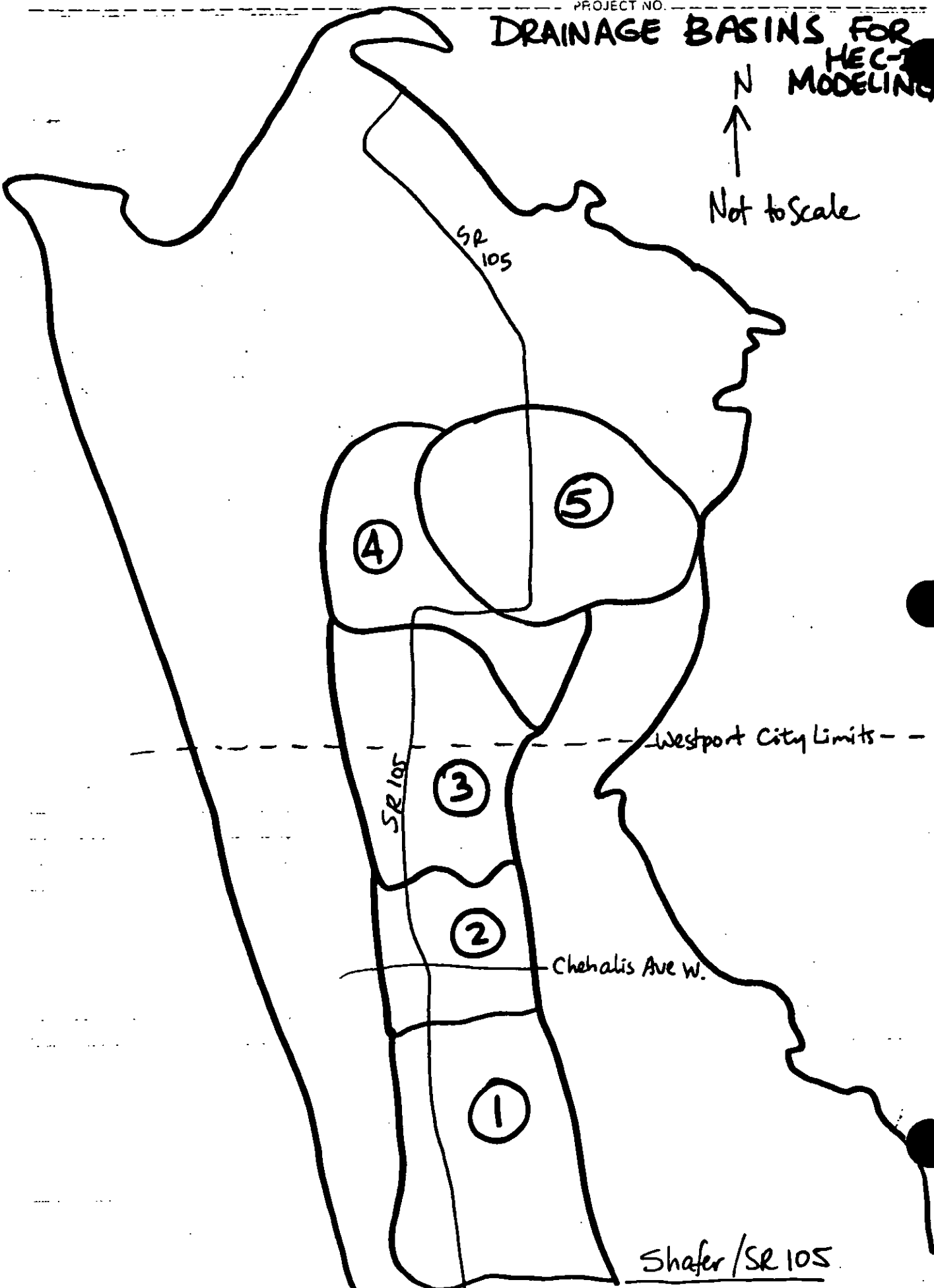

SR 105

④

⑤

③

②

①

Westport City Limits - -

Chehalis Ave W.

Shafer / SR 105

Input

*FREE										
ID	FILENAME: SCOAST1.DAT									
ID	SOUTH COASTAL FLOOD HAZARD REDUCTION PLAN									
ID	100-YR STORM FREQUENCY									
IT	5	29NOV96	0000	300						
IN	10	29NOV96	0000							
IO	5									
KK	BASIN_1									
BA	0.40									
*	2-YR, 24-HR PRECIP IS APPROX. 3.0" (NOAA ATLAS)									
PB	3.0									
LS	0	75.0								
PC	0.004	0.008	0.012	0.016	0.020	0.024	0.028	0.032	0.036	0.040
PC	0.045	0.050	0.055	0.060	0.065	0.070	0.076	0.082	0.088	0.094
PC	0.100	0.106	0.113	0.120	0.127	0.134	0.141	0.148	0.156	0.164
PC	0.173	0.181	0.189	0.197	0.207	0.216	0.226	0.235	0.245	0.254
PC	0.268	0.281	0.294	0.312	0.330	0.364	0.418	0.445	0.463	0.477
PC	0.490	0.504	0.512	0.521	0.530	0.539	0.548	0.556	0.565	0.574
PC	0.583	0.592	0.600	0.609	0.616	0.624	0.631	0.638	0.645	0.652
PC	0.660	0.667	0.674	0.681	0.688	0.696	0.701	0.707	0.713	0.718
PC	0.724	0.730	0.736	0.741	0.747	0.753	0.758	0.764	0.769	0.774
PC	0.779	0.784	0.789	0.794	0.799	0.804	0.809	0.814	0.819	0.824
PC	0.828	0.832	0.836	0.840	0.844	0.848	0.852	0.856	0.860	0.864
PC	0.868	0.872	0.876	0.880	0.884	0.888	0.892	0.896	0.900	0.904
PC	0.908	0.912	0.916	0.920	0.924	0.928	0.932	0.936	0.940	0.944
PC	0.948	0.952	0.956	0.960	0.964	0.968	0.972	0.976	0.980	0.984
PC	0.988	0.992	0.996	1.000						
UD	1.54									
KO	1									
KK	ROUTE BASIN_1 TO NODE_B									
RT	0	1	10	11						
KO	1									
KK	BASIN_2									
BA	0.13									
LS	0	63								
UD	0.41									
KO	1									
KK	NODE_B COMBINED HYDROGRAPH									
HC	2									
KO	1									
KK	ROUTE COMBINED HYDROGRAPH TO NODE_C									
RT	0	1	10	11						
KK	BASIN_3									
BA	0.36									
LS	0	63								
UD	1.81									
KO	1									
KK	NODE_C COMBINED HYDROGRAPH									
HC	2									
KO	1									
KK	ROUTE COMBINED HYDROGRAPH TO NODE_D									

Input

RT	0	1	<del>10</del> 5						
KK	BASIN_4								
BA	0.19								
LS	0	73							
UD	0.78								
KO	1								
KK	NODE_D COMBINED HYDROGRAPH								
HC	2								
KO	1								
KK	ROUTE NODE_D COMBINED HYDROGRAPH TO NODE_E								
RT	0	1	<del>10</del> 1A						
KO	1								
KK	BASIN_5								
BA	0.25								
LS	0	75.0							
UD	0.75								
KO	1								
KK	NODE_E COMBINED HYDROGRAPH								
HC	2								
KO	1								
ZZ									

29 NOV 0525	66	0.	*	29 NOV 1140	141	29.	*	29 NOV 1755	216	39.	*	30
NOV 0010	291	23.										
29 NOV 0530	67	0.	*	29 NOV 1145	142	30.	*	29 NOV 1800	217	39.	*	30
NOV 0015	292	23.										
29 NOV 0535	68	0.	*	29 NOV 1150	143	31.	*	29 NOV 1805	218	39.	*	30
NOV 0020	293	22.										
29 NOV 0540	69	0.	*	29 NOV 1155	144	32.	*	29 NOV 1810	219	39.	*	30
NOV 0025	294	22.										
29 NOV 0545	70	0.	*	29 NOV 1200	145	33.	*	29 NOV 1815	220	39.	*	30
NOV 0030	295	22.										
29 NOV 0550	71	0.	*	29 NOV 1205	146	35.	*	29 NOV 1820	221	39.	*	30
NOV 0035	296	22.										
29 NOV 0555	72	0.	*	29 NOV 1210	147	36.	*	29 NOV 1825	222	39.	*	30
NOV 0040	297	22.										
29 NOV 0600	73	0.	*	29 NOV 1215	148	38.	*	29 NOV 1830	223	39.	*	30
NOV 0045	298	22.										
29 NOV 0605	74	0.	*	29 NOV 1220	149	39.	*	29 NOV 1835	224	40.	*	30
NOV 0050	299	21.										
29 NOV 0610	75	0.	*	29 NOV 1225	150	41.	*	29 NOV 1840	225	39.	*	30
NOV 0055	300	21.										

\*\*\*\*\*  
\*\*\*\*\*

*2-yr*

PEAK FLOW + (CFS)	TIME (HR)	MAXIMUM AVERAGE FLOW			
		6-HR	24-HR	72-HR	24.92-HR
47.	13.08	44.	25.	24.	24.
	(INCHES)	.304	.698	.698	.698
	(AC-FT)	22.	50.	50.	50.

CUMULATIVE AREA = 1.33 SQ MI

1

RUNOFF SUMMARY  
FLOW IN CUBIC FEET PER SECOND  
TIME IN HOURS, AREA IN SQUARE MILES

BASIN STAGE	MAXIMUM TIME OF OPERATION STAGE	STATION	PEAK TIME OF AVERAGE FLOW FOR MAXIMUM PERIOD			AREA
			6-HOUR	24-HOUR	72-HOUR	
+						

+	HYDROGRAPH AT BASIN_1	21.	9.00	19.	10.	10.	.40
---	--------------------------	-----	------	-----	-----	-----	-----

*Reach*

	ROUTED TO						
+	ROUTE	21.	9.92	19.	10.	10.	.40
	HYDROGRAPH AT						
+	BASIN_2	3.	21.33	3.	2.	1.	.13
	2 COMBINED AT						
+	NODE_B	24.	9.92	21.	12.	11.	.53
	ROUTED TO						
+	ROUTE	24.	11.75	21.	11.	11.	.53
	HYDROGRAPH AT						
+	BASIN_3	7.	21.92	7.	4.	4.	.36
	2 COMBINED AT						
+	NODE_C	30.	11.83	28.	15.	15.	.89
	ROUTED TO						
+	ROUTE	30.	12.25	28.	15.	14.	.89
	HYDROGRAPH AT						
+	BASIN_4	11.	8.00	8.	4.	4.	.19
	2 COMBINED AT						
+	NODE_D	37.	12.33	35.	19.	19.	1.08
	ROUTED TO						
+	ROUTE	37.	13.50	35.	19.	18.	1.08
	HYDROGRAPH AT						
+	BASIN_5	19.	7.92	12.	6.	6.	.25
	2 COMBINED AT						
+	NODE_E	47.	13.08	44.	25.	24.	1.33

*Reach 2*

\*\*\* 1 ERROR(S) DETECTED BY HEC-1 \*\*\*

*← This is happening because the program thinks there is a quote-mark in the comment line (#9). Ignore. (TYP.)*

SCS.C  
 HEC-1 for  
 GH South Coastal FHPP  
 for 5-yr Event

RUNOFF SUMMARY  
 FLOW IN CUBIC FEET PER SECOND  
 TIME IN HOURS, AREA IN SQUARE MILES

MAXIMUM STAGE +	TIME OF OPERATION MAX STAGE	STATION	PEAK FLOW	TIME OF PEAK	AVERAGE FLOW FOR MAXIMUM PERIOD			BASIN AREA
					6-HOUR	24-HOUR	72-HOUR	
+	HYDROGRAPH AT	BASIN_1	43.	8.83	34.	18.	17.	.40
+	ROUTED TO	ROUTE	43.	9.75	34.	18.	17.	.40
+	HYDROGRAPH AT	BASIN_2	8.	7.75	6.	3.	3.	.13
+	2 COMBINED AT	NODE_B <sup>Node B</sup>	49.	9.58	40.	21.	20.	.53
+	ROUTED TO	ROUTE	49.	11.42	40.	20.	19.	.53
+	HYDROGRAPH AT	BASIN_3	15.	12.08	15.	9.	8.	.36
+	2 COMBINED AT	NODE_C	65.	11.50	54.	29.	28.	.89
+	ROUTED TO	ROUTE	65.	11.92	54.	28.	27.	.89
+	HYDROGRAPH AT	BASIN_4	25.	7.92	15.	8.	8.	.19
+	2 COMBINED AT	NODE_D	77.	11.83	66.	36.	35.	1.08
+	ROUTED TO	ROUTE	77.	13.00	66.	35.	34.	1.08
+	HYDROGRAPH AT	BASIN_5	38.	7.92	23.	11.	11.	.25
+	2 COMBINED AT	NODE_E	94.	12.92	80.	46.	44.	1.33

\*\*\* NORMAL END OF HEC-1 \*\*\*

3/5/97

SC10.01  
 HEC-I Run for  
 GH South Coastal FHI  
 for 10-yr Event

RUNOFF SUMMARY  
 FLOW IN CUBIC FEET PER SECOND  
 TIME IN HOURS, AREA IN SQUARE MILES

MAXIMUM STAGE +	TIME OF OPERATION MAX STAGE	STATION	PEAK FLOW	TIME OF PEAK	AVERAGE FLOW FOR MAXIMUM PERIOD			BASIN AREA
					6-HOUR	24-HOUR	72-HOUR	
+	HYDROGRAPH AT	BASIN_1	56.	8.75	43.	22.	21.	.40
+	ROUTED TO	ROUTE	56.	9.67	43.	22.	21.	.40
+	HYDROGRAPH AT	BASIN_2	12.	7.67	8.	4.	4.	.13
+	2 COMBINED AT	NODE_B <i>Newell</i>	64.	9.58	50.	26.	25.	.53
+	ROUTED TO	ROUTE	64.	11.42	50.	25.	24.	.53
+	HYDROGRAPH AT	BASIN_3	21.	11.58	20.	12.	11.	.36
+	2 COMBINED AT	NODE_C	85.	11.42	69.	36.	35.	.89
+	ROUTED TO	ROUTE	85.	11.83	69.	36.	35.	.89
+	HYDROGRAPH AT	BASIN_4	33.	7.92	19.	10.	9.	.19
+	2 COMBINED AT	NODE_D	100.	11.75	83.	46.	44.	1.08
+	ROUTED TO	ROUTE	100.	12.92	83.	44.	42.	1.08
+	HYDROGRAPH AT	BASIN_5	49.	7.83	28.	14.	13.	.25
+	2 COMBINED AT	NODE_E	120.	12.83	100.	58.	56.	1.33

3/27

29 NOV 0525	66	4.	*	29 NOV 1140	141	109.	*	29 NOV 1755	216	94.	*	30
NOV 0010	291	53.										
29 NOV 0530	67	5.	*	29 NOV 1145	142	111.	*	29 NOV 1800	217	94.	*	30
NOV 0015	292	52.										
29 NOV 0535	68	5.	*	29 NOV 1150	143	113.	*	29 NOV 1805	218	94.	*	30
NOV 0020	293	51.										
29 NOV 0540	69	5.	*	29 NOV 1155	144	116.	*	29 NOV 1810	219	94.	*	30
NOV 0025	294	51.										
29 NOV 0545	70	6.	*	29 NOV 1200	145	119.	*	29 NOV 1815	220	94.	*	30
NOV 0030	295	51.										
29 NOV 0550	71	6.	*	29 NOV 1205	146	123.	*	29 NOV 1820	221	94.	*	30
NOV 0035	296	50.										
29 NOV 0555	72	7.	*	29 NOV 1210	147	127.	*	29 NOV 1825	222	94.	*	30
NOV 0040	297	50.										
29 NOV 0600	73	8.	*	29 NOV 1215	148	130.	*	29 NOV 1830	223	94.	*	30
NOV 0045	298	49.										
29 NOV 0605	74	9.	*	29 NOV 1220	149	134.	*	29 NOV 1835	224	94.	*	30
NOV 0050	299	49.										
29 NOV 0610	75	10.	*	29 NOV 1225	150	137.	*	29 NOV 1840	225	94.	*	
30 NOV 0055	300	48.										

\*\*\*\*\*  
\*\*\*\*\*

25-YR

PEAK FLOW + (CFS)	TIME (HR)	MAXIMUM AVERAGE FLOW			
		6-HR	24-HR	72-HR	24.92-HR
148.	12.83	122.	70.	68.	68.
	(CFS)				
	(INCHES)	.855	1.963	1.963	1.963
	(AC-FT)	61.	139.	139.	139.

CUMULATIVE AREA = 1.33 SQ MI

1

RUNOFF SUMMARY  
FLOW IN CUBIC FEET PER SECOND  
TIME IN HOURS, AREA IN SQUARE MILES

BASIN STAGE	MAXIMUM OPERATION MAX STAGE	TIME OF STATION	PEAK TIME OF AVERAGE FLOW FOR MAXIMUM PERIOD			AREA	
			FLOW	PEAK			
+			6-HOUR	24-HOUR	72-HOUR		
+	HYDROGRAPH AT BASIN_1	69.	8.75	52.	26.	25.	.40

+	ROUTED TO ROUTE	69.	9.67	52.	26.	25.	.40
+	HYDROGRAPH AT BASIN_2	17.	7.50	10.	5.	5.	.13
+	2 COMBINED AT NODE_B	79.	9.58	60.	31.	30.	.53
+	ROUTED TO ROUTE	79.	11.42	60.	30.	29.	.53
+	HYDROGRAPH AT BASIN_3	27.	9.67	26.	14.	14.	.36
+	2 COMBINED AT NODE_C	106.	11.42	85.	45.	43.	.89
+	ROUTED TO ROUTE	106.	11.83	85.	44.	42.	.89
+	HYDROGRAPH AT BASIN_4	41.	7.92	24.	12.	11.	.19
+	2 COMBINED AT NODE_D	124.	11.75	101.	56.	54.	1.08
+	ROUTED TO ROUTE	124.	12.92	101.	54.	52.	1.08
+	HYDROGRAPH AT BASIN_5	60.	7.83	34.	16.	16.	.25
+	2 COMBINED AT NODE_E	148.	12.83	122.	70.	68.	1.33

\*\*\* 1 ERROR(S) DETECTED BY HEC-1 \*\*\*

29 NOV 0525	66	9.	*	29 NOV 1140	141	159.	*	29 NOV 1755	216	123.	*
30 NOV 0010	291	69.									
29 NOV 0530	67	10.	*	29 NOV 1145	142	161.	*	29 NOV 1800	217	123.	*
30 NOV 0015	292	68.									
29 NOV 0535	68	10.	*	29 NOV 1150	143	163.	*	29 NOV 1805	218	123.	*
30 NOV 0020	293	67.									
29 NOV 0540	69	11.	*	29 NOV 1155	144	167.	*	29 NOV 1810	219	123.	*
30 NOV 0025	294	66.									
29 NOV 0545	70	12.	*	29 NOV 1200	145	171.	*	29 NOV 1815	220	123.	*
30 NOV 0030	295	66.									
29 NOV 0550	71	13.	*	29 NOV 1205	146	176.	*	29 NOV 1820	221	123.	*
30 NOV 0035	296	65.									
29 NOV 0555	72	14.	*	29 NOV 1210	147	180.	*	29 NOV 1825	222	123.	*
30 NOV 0040	297	65.									
29 NOV 0600	73	15.	*	29 NOV 1215	148	185.	*	29 NOV 1830	223	123.	*
30 NOV 0045	298	64.									
29 NOV 0605	74	17.	*	29 NOV 1220	149	189.	*	29 NOV 1835	224	123.	*
30 NOV 0050	299	63.									
29 NOV 0610	75	19.	*	29 NOV 1225	150	194.	*	29 NOV 1840	225	123.	*
30 NOV 0055	300	62.									

\*\*\*\*\*  
\*\*\*\*\*

100-yr

PEAK FLOW + (CFS)	TIME (HR)	MAXIMUM AVERAGE FLOW			
		6-HR	24-HR	72-HR	24.92-HR
206.	12.83	170.	97.	93.	93.
	(CFS)				
	(INCHES)	1.186	2.699	2.699	2.699
	(AC-FT)	84.	191.	191.	191.

CUMULATIVE AREA = 1.33 SQ MI

1

RUNOFF SUMMARY  
FLOW IN CUBIC FEET PER SECOND  
TIME IN HOURS, AREA IN SQUARE MILES

BASIN STAGE	MAXIMUM MAX STAGE	OPERATION STATION	PEAK TIME OF AVERAGE FLOW FOR MAXIMUM PERIOD			AREA		
			6-HOUR	24-HOUR	72-HOUR			
+			97.	8.67	70.	35.	34.	.40

HYDROGRAPH AT  
BASIN\_1

	ROUTED TO						
+	ROUTE	97.	9.58	70.	35.	34.	.40
	HYDROGRAPH AT						
+	BASIN_2	29.	7.42	15.	8.	7.	.13
	2 COMBINED AT						
+	NODE_B	113.	9.50	83.	43.	41.	.53
	ROUTED TO						
+	ROUTE	113.	11.33	83.	41.	39.	.53
	HYDROGRAPH AT						
+	BASIN_3	44.	9.42	38.	21.	20.	.36
	2 COMBINED AT						
+	NODE_C	151.	11.33	118.	62.	60.	.89
	ROUTED TO						
+	ROUTE	151.	11.75	118.	61.	59.	.89
	HYDROGRAPH AT						
+	BASIN_4	58.	7.92	33.	16.	15.	.19
	2 COMBINED AT						
+	NODE_D	176.	11.67	141.	77.	74.	1.08
	ROUTED TO						
+	ROUTE	176.	12.83	141.	74.	72.	1.08
	HYDROGRAPH AT						
+	BASIN_5	85.	7.83	46.	22.	21.	.25
	2 COMBINED AT						
+	NODE_E	206.	12.83	170.	97.	93.	1.33

\*\*\* 1 ERROR(S) DETECTED BY HEC-1 \*\*\*

24-Hour Storm Interval  
Peak Flows (cfs)

	2-yr	25-yr	100-yr
<b>Reach 2</b>	21	69	97
<b>Reach 3</b>	24	79	113
<b>Reach 4</b>	30	106	151
<b>Reach 5</b>	37	124	176
<b>Tide Gates</b>	47	148	206

HEC-1 Peak Flows

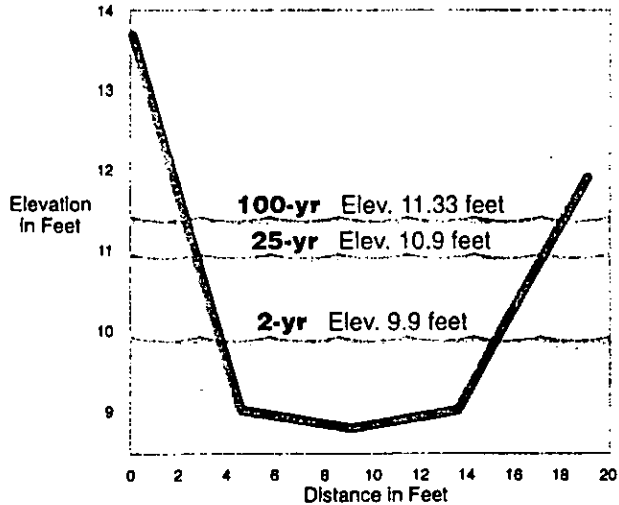

Reach 3 Sample Cross Section

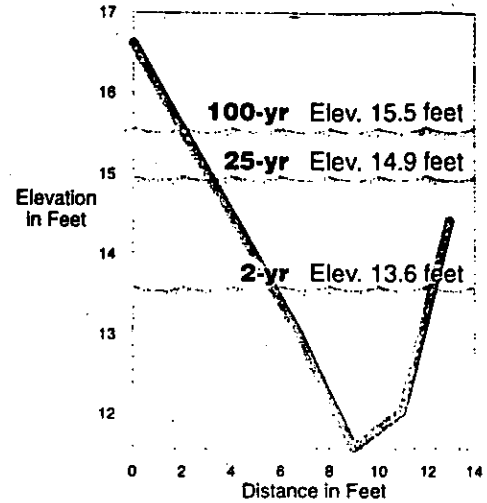

Reach 2 Sample Cross Section

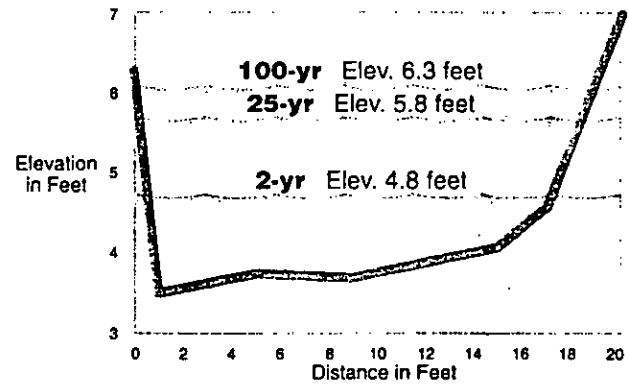

Reach 5 Sample Cross Section

**South Coastal Flood Hazard Reduction Plan  
Grays Harbor County**